

EEG-Based Brain-Controlled Mobile Robots

¹K.K. Kulkarni, ²Prof. D.S.Bhosale

Department of Electronics and Telecommunication, Bhivarabai Sawant Institute of Technology and Research, Pune, India

Abstract: The focus of this paper is brain controlled mobile robots using key techniques like brain computer interfaces techniques and shared control techniques .this mobile robots different than other mobile robots. this mobile robot specially for handicapped or disable person. The complete system is divided into three parts BCI system, data processing unit, robotic module. In this we provide proposed system are Brain wave analysis Robot control using Human thoughts Self-controlled and operating facility, Bluetooth communication.

Keywords: Brain-computer interface (BCI), brain-controlled *mobile* robot, EEG.

I. INTRODUCTION

This project is about a brain controlled robot based on Brain-computer interfaces (BCI). BCIs are systems that can bypass conventional channels of communication (i.e., muscles and thoughts) to provide direct communication and control between the human brain and physical devices by translating different patterns of brain activity into commands in real time. With these commands a mobile robot can be controlled. The intention of the project work is to develop a robot that can assist the disabled people in their daily life to do some work independent of others. Here, we analyze the brain wave signals. Human brain consists of millions of interconnected neurons. The pattern of interaction between these neurons is represented as thoughts and emotional states. According to the human thoughts, this pattern will be changing which in turn produce different electrical waves. A muscle contraction will also generate a unique electrical signal [1] all these electrical waves will be sensed by the brain wave sensor and it will convert the data into packets and transmit through Bluetooth medium. Level analyser unit (LAU) will receive the brain wave raw data and it will extract and process the signal using MATLAB platform. Then the control commands will be transmitted to the robot module to process. With this entire system, we can move a robot according to the human thoughts and it can be turned by blink muscle contraction [3].

II. LITERATURE SURVEY

An EEG-based brain-controlled robot is a robot that uses EEG-based BCIs to receive human control (hereafter, brain controlled robots refer to EEG-based brain-controlled robots only). Two main classes of brain-controlled robots to assist disabilities are brain-controlled manipulators and mobile robots. One representative work of brain-controlled manipulators is the manipulator used within the FRIEND system developed by Graser et al, which is able to show the brain controlled capabilities of robots out of a controlled laboratory Situation. Compared with other brain-controlled devices, the major difference of brain-controlled mobile robotic systems is that these mobile robots require higher safety since they are used to transport disabled people. Thus, the BCI systems that are used to develop these robots need better performance (i.e., higher accuracy and shorter classification time). Recently, research and development of brain-controlled mobile robots have received a great deal of attention because of their ability to bring mobility back to people with devastating neuromuscular disorders and improve the quality of life and self-independence of these users. In 2004, the first EEG based brain-controlled mobile robot was proposed by Mill'an *et al.* Since then, many researchers have developed various brain-controlled mobile robots. Number of published papers on brain-controlled mobile robots between 2004 and 2011. Although nearly a hundred papers have been published during this period, no comprehensive literature review can be found that covers brain-controlled mobile robots Either in the robotics or the BCI literature, with the possible exception of two papers. Mill'an gave a brief introduction of the issues and challenges of brain-controlled robots. Recently, Mill'an *et al.* reviewed the challenges that are faced by BCI-based assistive technology and its applications including communication and control, motor substitution, entertainment, And motor recovery.

III. DESIGN & IMPLEMENTATION

This paper is implemented in an effective way we divide brain-controlled mobile robots into two categories according to their operational modes. One category is called “direct control by the BCI,” which means that the BCI translates EEG signals into motion commands to control robots directly who first developed a brain-controlled robotic wheelchair. Whose left or right turning movements are directly controlled by corresponding motion commands translated from user brain signals while imagining left or right limb movements, and tested this system in real-world situations [5]. The Robotic platform is illustrated also used a BCI based on motor imagery to build a brain-controlled mobile robot, as illustrated which can perform three motion commands including turning left and right and going forward, and validated this robot in a real world. Brain secret card section contains EEG Sensor to Sense the Human brain, and it will be sensed by using the Brainwave Headset which is provided by NeuroSky. Technologies and those signals will be transferred by using Bluetooth which is there in the Brainwave headset, for this Brainwave headset we need to give power using a AAA battery which is shown in figure 2. The Brainwave headset comes with Power switch, a sensor tip, flexible ear arm and a ground connection Ear clip. In this Headset we use Non-invasive sensor that won't cause any pain to the User who were the headset. After inserting an AAA battery switch on the Brainwave headset using the power switch the LED indicator will blink and if the Red colour light not blinking the headset is powered on but not connected to with the computer's Bluetooth. If the Blue colour not blinking that means the headset is powered on and connected. If the red or blue colour blinks it shows that the Battery getting low.

B. Overall System Diagram:

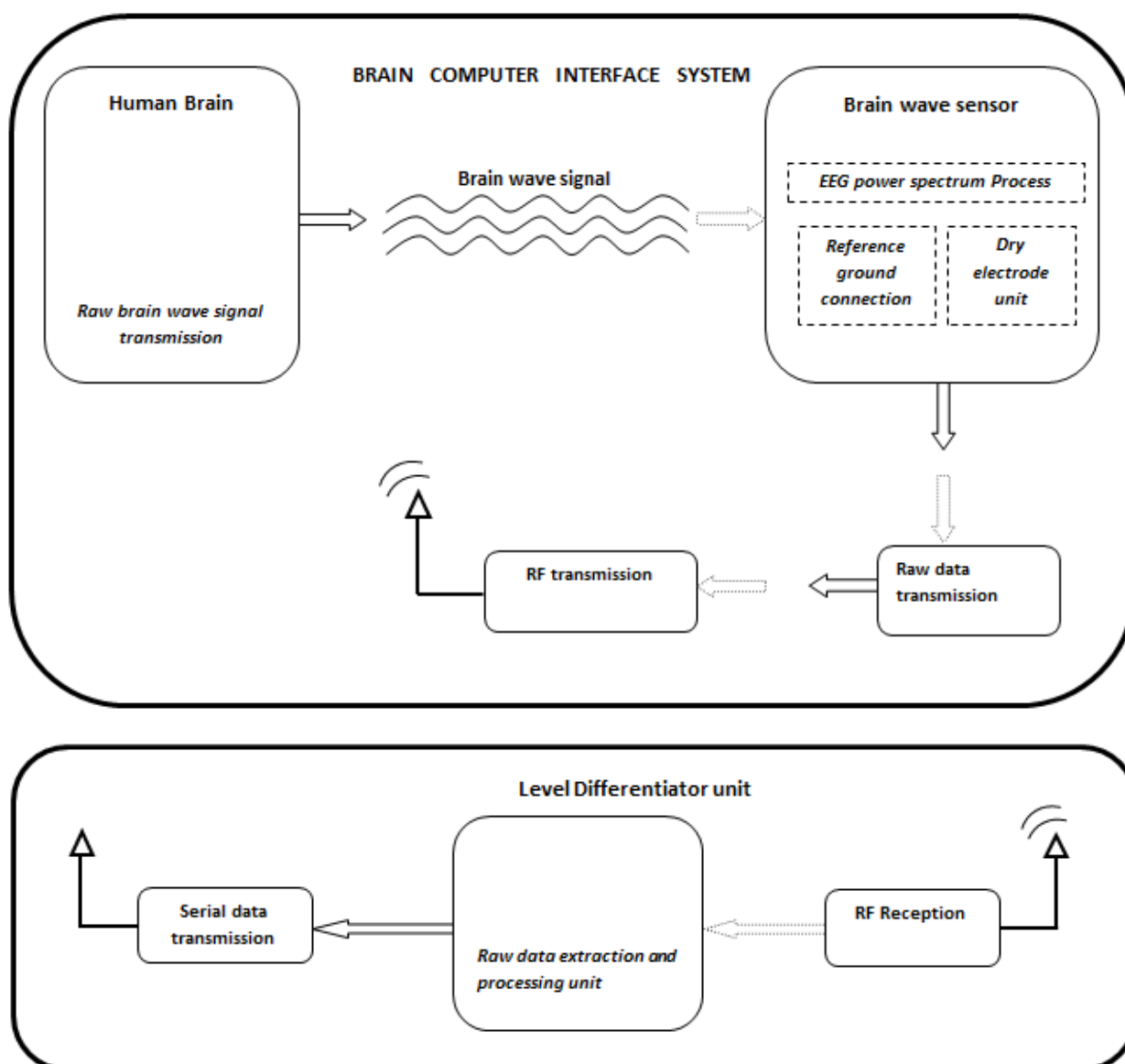

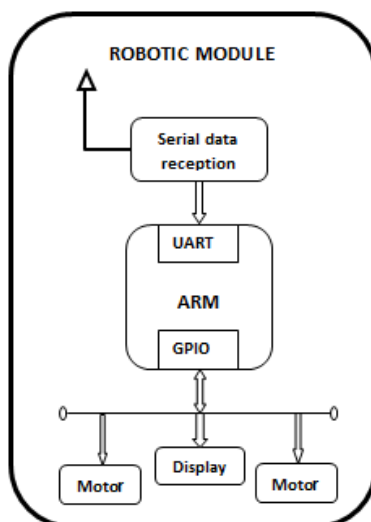

IV. RESULTS

The research and development of brain-controlled mobile robots have received a great deal of attention because they can help bring mobility back to people with devastating neuromuscular disorders and thus improve their quality of life. In this paper, we presented a comprehensive up-to-date review of the complete systems, key techniques, and evaluation issues of brain-controlled mobile robots. After implementing the Mindwave Controlled robot I've checked the results with NeuroSky headset, as I expected the headset doesn't give the 100% accuracy of brainwaves but it is too good for its price and it can give up to 95% accuracy of brainwaves. After installing all the Neurosky software's in PC, after connecting the Headset with PC through PC using Bluetooth, we need to wear the headset to the head and then we need to open the Mat lab Code and run the program, after clicking run the program in the command window of mat lab it will show the brainwave is connected and blink is detected and after that it will show the attention values and Blink values After getting these attention and blink values a graph will be generated and In the graph there will be two signals, the Black Signal is Blinking level and the red signal is Attention signal. From here these signals will be transferred to the Robot through Zigbee wireless transmission, the signals will be collected by Zigbee receiver and sends to the processor, the processor decodes the signals as per Brainwave signals and according to the signals the Processor gives the commands to the motor wheels of the robot, according to the signals the robot will move forward, Right and left and the robot is self-controlled.

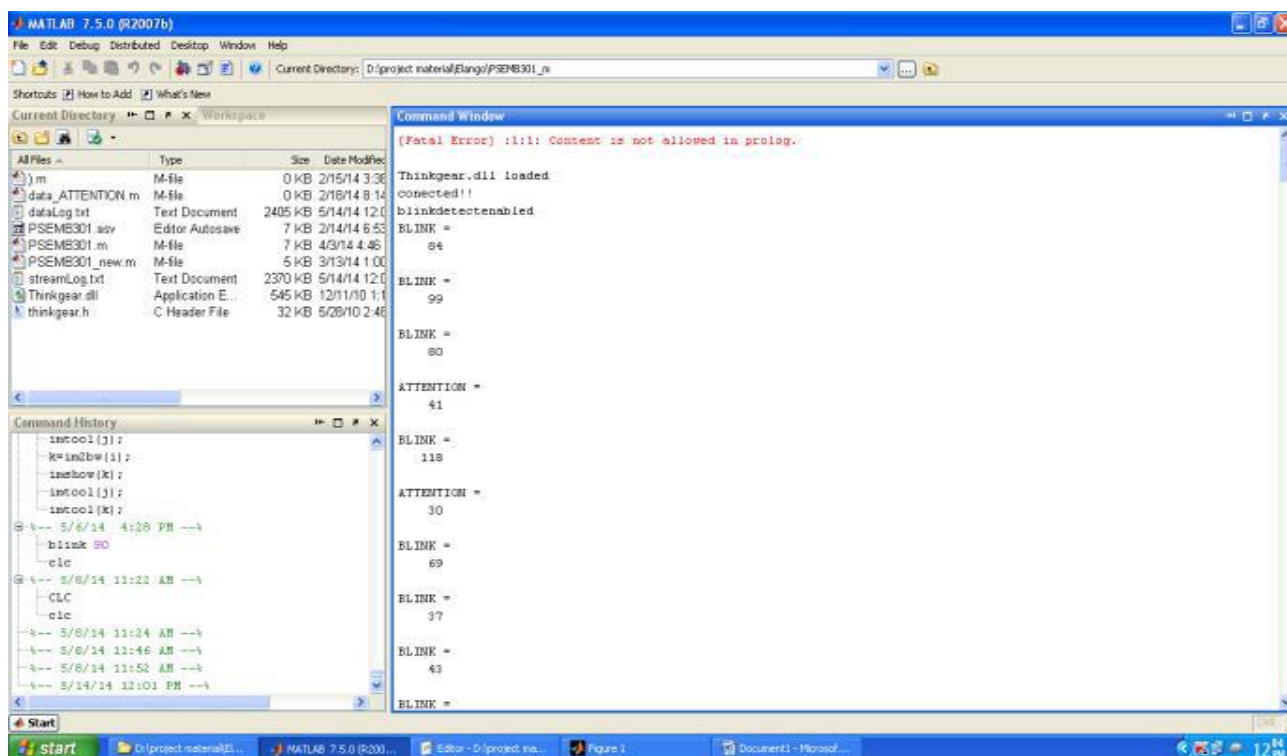

Attention level and Blink level

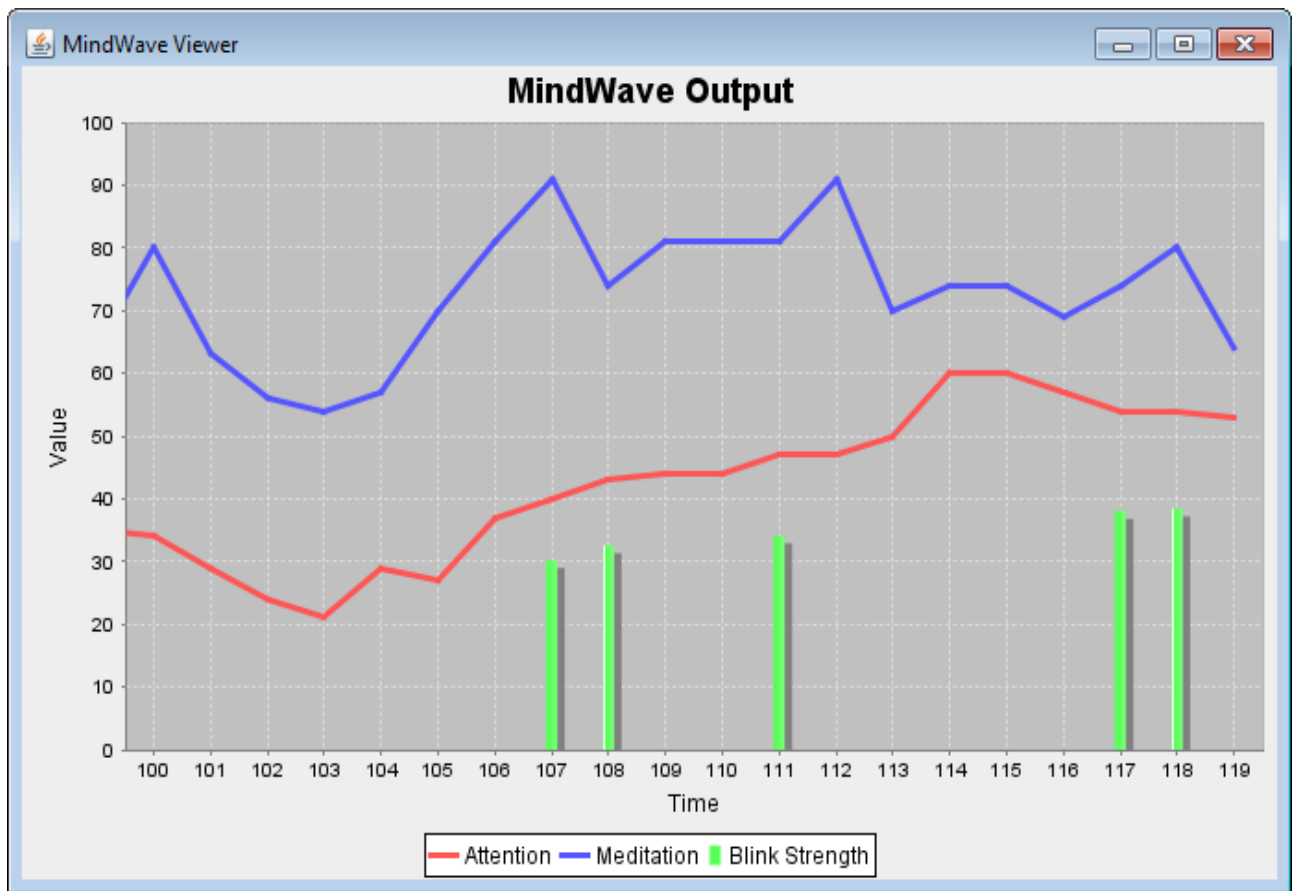
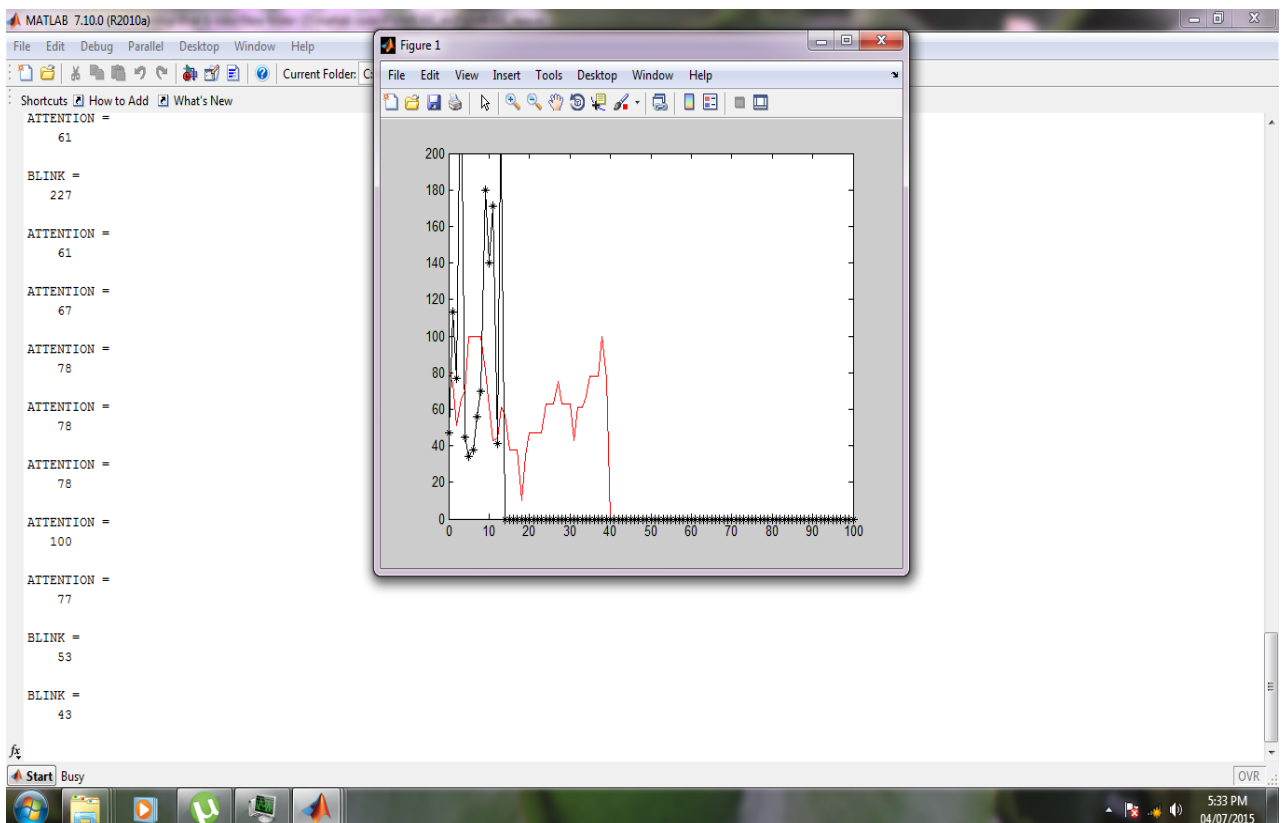

Fig.The Mind Wave Brainwave Chart.



V. CONCLUSION

This Brain controlled mobile robots require higher safety because they are used to transport disabled people. This is major difference between brain-controlled mobile robots and other brain-controlled devices. In this paper BCI systems have been developed to address these challenges. BCIs are systems that can bypass conventional channels of communication. These mobile robots having applications are, Automotive Applications, Industrial Application, Home applications, Monitoring device applications, Remote control applications. Mobile robot does not need of any additional robot intelligence. Cost is less also computational complexity are low. Having various applications such as Industrial Application Home applications Automotive Applications, Monitoring, device applications, Remote control applications

REFERENCES

- [1] "Brain controlled wheelchairs: A Robotic Architecture", Tom Carlson & Jose Del R. Millan, IEEE Robotics & Automation Magazine, March 2013
- [2] "Brain-Computer Interfaces & Human-Computer Interaction", Desney Tan & Anton Nijholt, Springer-Verlag London Limited, 2010
- [3] X. Perrin, "Semi-autonomous navigation of an assistive robot using low throughput interfaces," Ph.D. dissertation, ETHZ, Zurich, Switzerland, 2009
- [4] B. Rebsamen, C. Guan, H. Zhang, C. Wang, C. Teo, M. H. Ang, Jr., and E. Burdet, "A brain controlled wheelchair to navigate in familiar environments," *IEEE Trans. Neural Syst. Rehabil. Eng.*, vol. 18, no. 6, pp. 590–598, Dec. 2010. vol. 20, no. 4, pp. 508–515, 2006
- [5] "A Brain-Computer Interface using electrocorticographic signals in Humans", Eric C Leuthardt, Gerwin Schalk, Jonathan R Wolpaw, Jeffrey G Ojemann & Daniel W Moran IOP Publishing Ltd, 2004